

PLANS

MIRANO

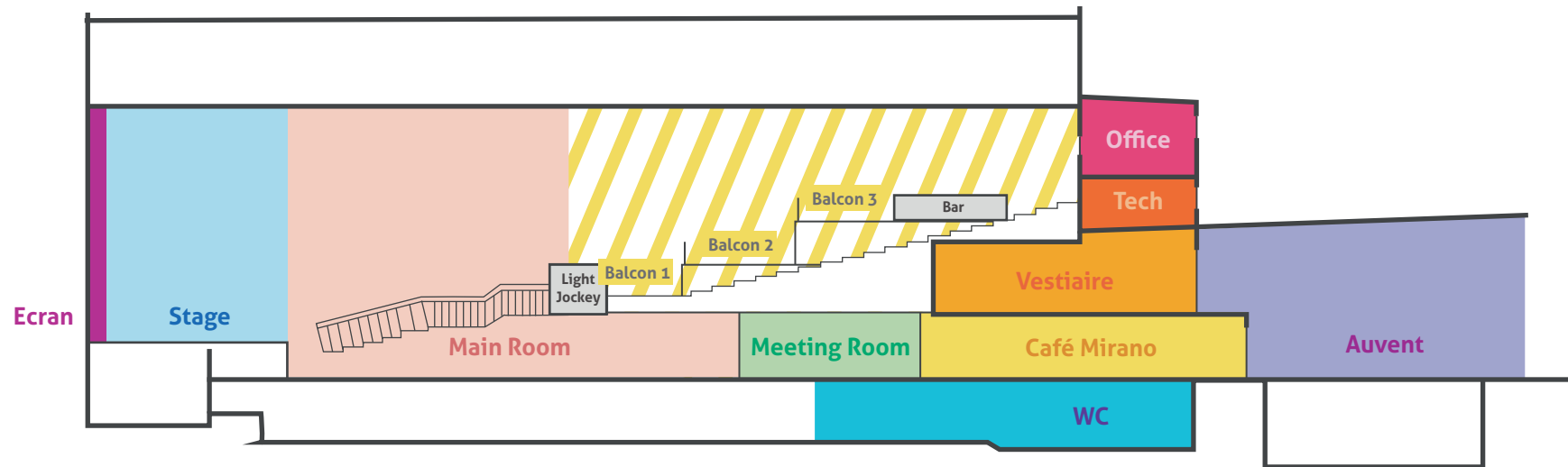

ELÉVATION



REZ DE CHAUSSÉE

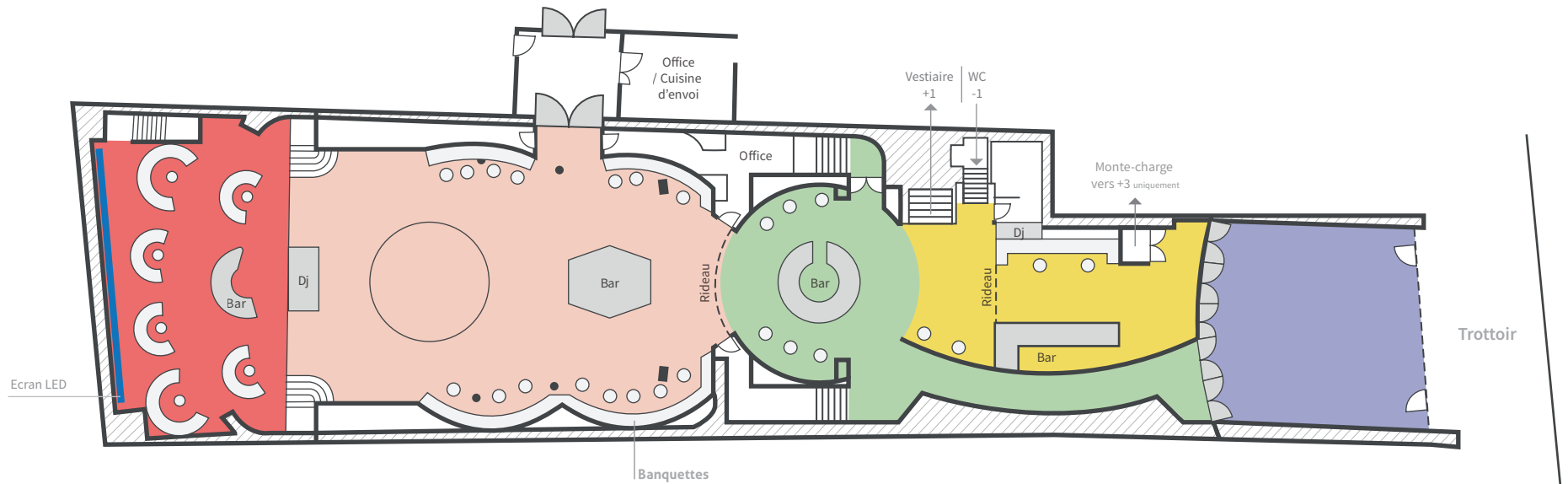

VIP / Stage
95 m²

Main Room
209.50 m²

Meeting Room
59 m²

Café Mirano
64 m²

Auvent
83 m²

NIVEAU +1

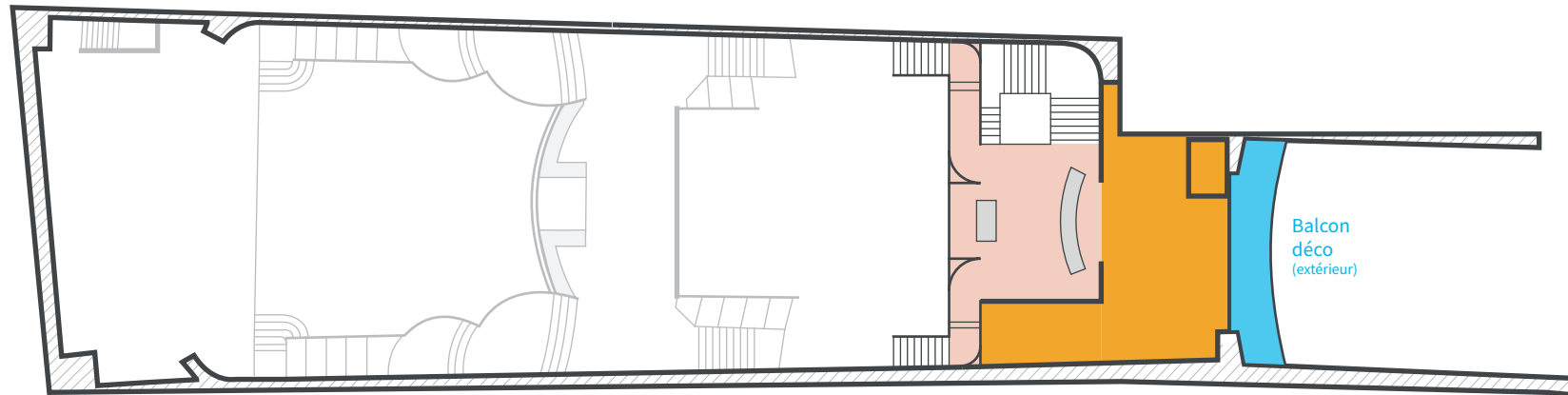

Lobby Vestiaire
79.50 m²

BALCONS

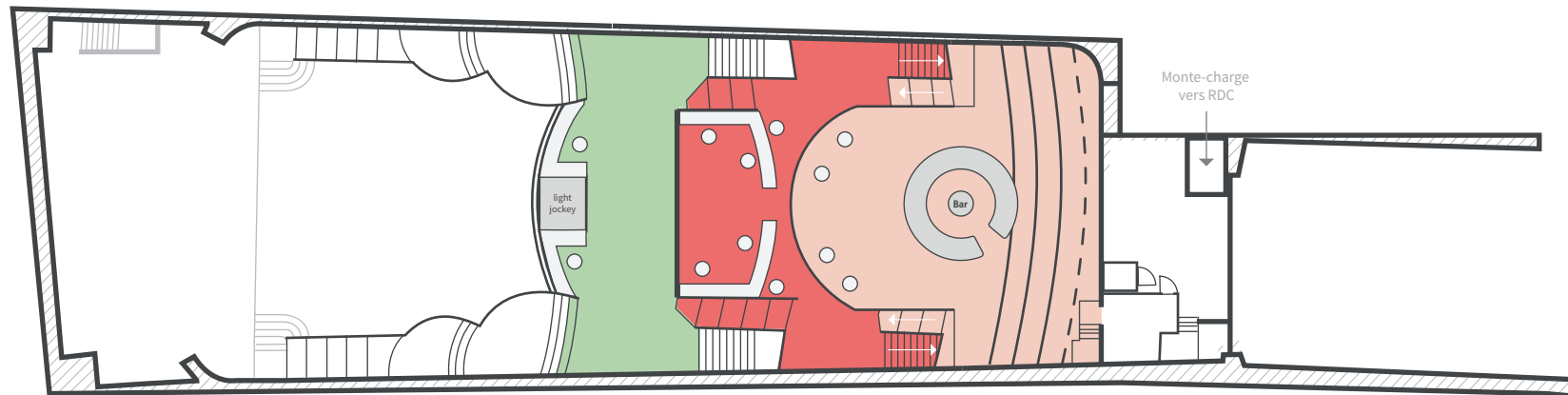

Balcon 1
niveau +1

67.50 m²

Balcon 2
niveau +2

35 m²

Balcon 3
niveau +3

61 m²

SOUS-SOL

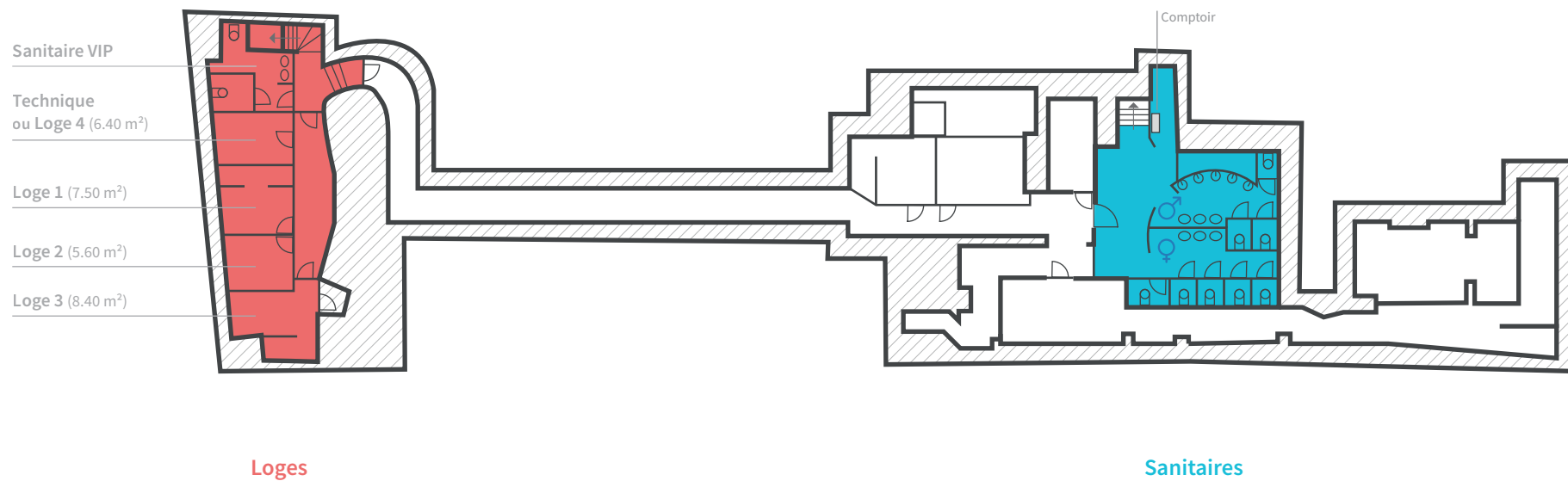

PLAN D'ACCÈS

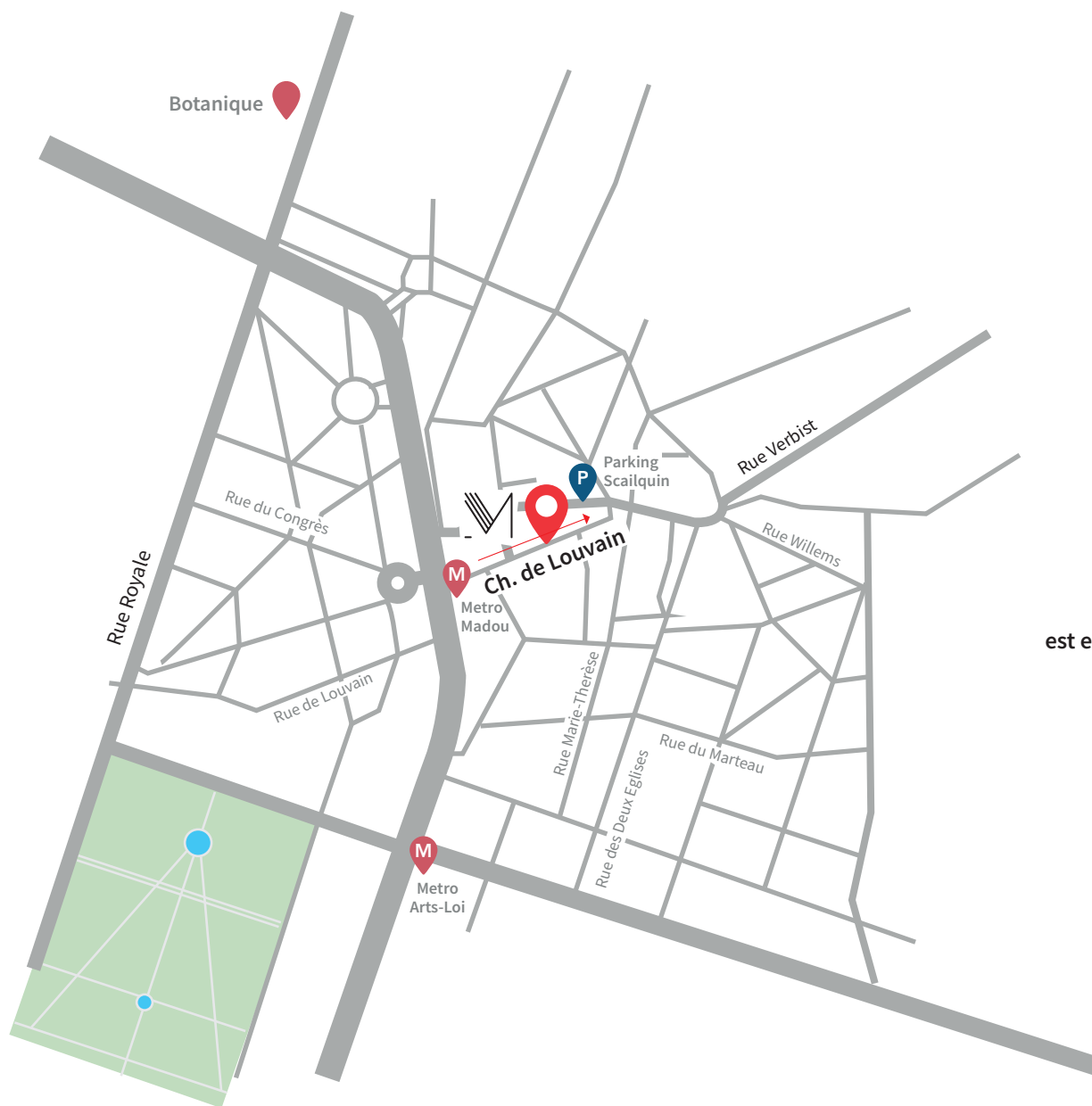

La Chaussée de Louvain
est en sens unique de 7 à 19H
du lundi au vendredi